

## 2 GALLON QMG TANKS (GALVANIZED)

**IMPORTANT:** Read and follow all instructions and **SAFETY PRECAUTIONS** before using this equipment. Retain for future reference.

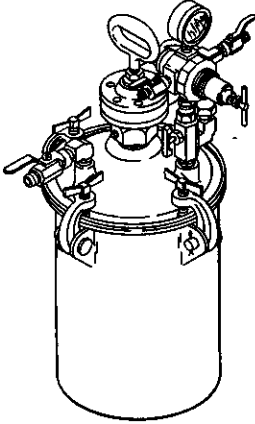

### DESCRIPTION

DeVilbiss pressure feed tanks are intended for use as a pressure container to supply material at a constant preset pressure up to a maximum of 110 psi. The tanks are built to ASME specifications. DeVilbiss pressure tanks are also certified for vacuum operation.

### WARNING

Halogenated hydrocarbon solvents - for example: 1, 1, 1, - trichloroethane and methylene chloride - can chemically react with aluminum parts and components and cause an explosion hazard. These solvents will also corrode the galvanized tank coating. Read the label or data sheet for the material. Do not use materials containing these solvents with these pressure tanks. Stainless steel tank models may be used with halogenated solvents.

### STANDARD NONREGULATED TANKS (No Regulation)

Standard type tank for use to distribute "regulated" air by remote filter/regulator or other similar control to pressure tank. Equipped with pressure gauge, safety valve, air bleed down valve, and air inlet valve.

### STANDARD FLUID REGULATED TANKS (Single Regulation)

Standard type tanks for use on jobs where precision control of both fluid and atomization air pressures is not required. Also used

where atomization air can be taken from filter/regulator air lines. Provides standard fluid pressure control only. Equipped with pressure regulator, pressure gauge, air bleed down valve, safety valve, and inlet and outlet air valves. (For conversion to double regulation, use kit QMS-436.)

### STANDARD AIR AND FLUID REGULATED TANKS (Dual Regulation)

Precision controlled tanks for use with materials that are best applied at low, closely controlled, fluid and atomization air pressures. Used with portable air compressors or with air lines when no other means of air pressure regulation is available. Equipped with two regulators (one for fluid pressure, the other for atomization air pressure), two pressure gauges, air bleed down valve, safety valve, and inlet and outlet valves.

### EXTRA SENSITIVE FLUID REGULATION

Tanks especially adapted for use with electrostatic spray installations, application of lubricants, special coatings, etc. Suitable for use wherever extremely sensitive, non-fluctuating low pressure control is required. Large, reinforced, synthetic diaphragm type regulator controls to a maximum of 30 pounds pressure. Equipped with extra sensitive pressure regulator, pressure gauge, air bleed down valve, safety valve, inlet valve, and unregulated outlet valve.

### AGITATION

Pressure tanks can be equipped with different types of fluid agitation, or no agitation. Hand agitation or air agitators are provided to suit any application.

### CAUTION

Refer to specifications chart to ensure that fluids and solvents being used are chemically compatible with the tank wetted parts. Before placing fluids or solvents in tank always read accompanying manufacturer's literature.

### WARNING

Air pressure loads that are higher than design loads, or changes to the pressure feed tank, can cause the tank to rupture or explode.

- A safety valve protects the tank from overpressurization. During each use, pull ring on the safety valve to make sure it operates freely and relieves air pressure. If the valve is stuck, does not operate freely, or does not relieve air pressure, it must be replaced with a safety valve having the same rating. Do not eliminate, make adjustments to, or substitutions to this valve.

- Changes to the air tank will weaken it. Never drill into, weld, or change the tank in any way.

- Maximum working pressure of this tank is 110 psi.

### MODEL NUMBERS

The model numbers are coded with specific information for each character and position in the number. Refer to the following table for an explanation of each position and meaning for each character in the model number. Use this information in selecting the proper model from the MODEL APPLICATION TABLE.

Character	Meaning
QMG	PRODUCT IDENTIFICATION
G	GALVANIZED
S	STAINLESS STEEL
T	TOP FLUID OUTLET
	COMPLETELY FACTORY ASSEMBLED
2	TANK SIZE - 2-GAL
5	TANK SIZE - 5-GAL
10	TANK SIZE - 10-GAL
15	TANK SIZE - 15-GAL
0	TYPE OF REGULATION - NONE
1	TYPE OF REGULATION - ONE REGULATOR
2	TYPE OF REGULATION - TWO REGULATORS
3	TYPE OF REGULATION - EXTRA-SENSITIVE
0	TYPE OF AGITATION - NONE
1	TYPE OF AGITATION - DIRECT DRIVE (2-GAL ONLY)
2	TYPE OF AGITATION - HAND
3	TYPE OF AGITATION - QS-5012 (STD)
6	TYPE OF AGITATION - QSR-503 (RECIPRO-CATING)

**SAFETY PRECAUTIONS**

This manual contains important information that all users should know and understand before using the equipment. This information relates to **USER SAFETY** and **PREVENTING EQUIPMENT PROBLEMS**. To help you recognize this information, we use the following terms to draw your attention to certain equipment labels and portions of this Service Bulletin. Please pay special attention to any label or information that is highlighted by one of these terms.



Important information to alert you to a situation that might cause serious injury if instructions are not followed.







Important information that tells how to prevent damage to equipment, or how to avoid a situation that might cause minor injury.

**Note**

Information that you should pay special attention to.



The following hazards may occur during the normal use of this equipment. Please read the following chart.

HAZARD	CAUSE	SAFEGUARDS
<p>Fire</p> 	<p>Solvents and coatings can be highly flammable or combustible, especially when sprayed.</p>	<ol style="list-style-type: none"> <li>1. Adequate exhaust must be provided to keep the air free of accumulations of flammable vapors.</li> <li>2. Smoking must never be allowed in the spray area.</li> <li>3. Fire extinguishing equipment must be present in the spray area.</li> </ol>
<p>Fire - Pressure Tank</p> 	<p>Vapors from flammable liquids can catch fire or explode.</p>	<ol style="list-style-type: none"> <li>1. Keep tank at least 10 feet away from sources of ignition. Ignition sources include hot objects, mechanical sparks, and arcing (non-explosion proof) electrical equipment.</li> </ol>
<p>Inhaling Toxic Substances</p> 	<p>Certain materials may be harmful if inhaled, or if there is contact with the skin.</p>	<ol style="list-style-type: none"> <li>1. Follow the requirements of the Material Safety Data Sheet supplied by your coating material manufacturer.</li> <li>2. Adequate exhaust must be provided to keep the air free of accumulations of toxic materials.</li> <li>3. Use a mask or respirator whenever there is a chance of inhaling sprayed materials. The mask must be compatible with the material being sprayed and its concentration. Equipment must be as prescribed by an industrial hygienist or safety expert, and be NIOSH approved.</li> </ol>
<p>Explosion Hazard - Pressure Tank - Rupture</p> 	<p>Making changes to pressure tank will weaken it.</p>	<ol style="list-style-type: none"> <li>1. Never drill into, weld, or modify tank in any way.</li> <li>2. Do not adjust, remove, or tamper with the safety valve. If replacement is necessary, use the same type and rating of valve.</li> </ol>
<p>General Safety</p>	<p>Improper operation or maintenance may create a hazard.</p>	<p>Operators should be given adequate training in the safe use and maintenance of the equipment (in accordance with the requirements of NFPA-33, Chapter 15 in U.S.). Users must comply with all local and national codes of practice and insurance company requirements governing ventilation, fire precautions, operation, maintenance and housekeeping (in the U.S., these are OSHA Sections 1910.94 and 1910.107, and NFPA-33).</p>

Model Number 2 Gallon	Agitator Type/Drive	Regulator	
		Type	Number
QMGT-5200	None	None	QMS-4003
QMGT-5210	None	Single	QMS-4006
QMGT-5220	None	Double	QMS-4007
QMGT-5202	Hand/Crank	None	QMS-4003
QMGT-5212	Hand/Crank	Single	QMS-4006
QMGT-5222	Hand/Crank	Double	QMS-4007
QMGT-5213	Std/Air	Single	QMS-4006
QMGT-5223	Std/Air	Double	QMS-4007
QMGT-5216	Recip/Air	Single	QMS-4006
QMGT-5226	Recip/Air	Double	QMS-4007
QMGT-5230	None	Ex Sen	QMS-4010
QMGT-5231	Dir Dr/Air	Ex Sen	QMS-4010
QMGT-5201	Dir Dr/Air	None	QMS-4003
QMGT-5211	Dir Dr/Air	Single	QMS-4006
QMGT-5221	Dir Dr/Air	Double	QMS-4007

**SPECIFICATIONS**

Maximum Working Pressure.....	110 psi
Tank Shell.....	SA-414 H.R. Steel Zinc Plate 12 gauge (0.105 in.) thick
Tank Lid.....	SA-414 H.R. Steel Zinc Plate 3/16 in. thick
Agitator Shaft.....	CRS Zinc Plate
Fluid tube.....	Galvanized Zinc Plate 3/8 in. pipe
Fluid Valve, Outlet.....	Brass 3/8-18 NPSM outlet
Air Manifold.....	CRS - Zinc Plated
Shaft Seal.....	Engineered Teflon, Stainless Steel
Agitator Paddles.....	Nylon
Fluid Outlet.....	Galvanized Steel Zinc Plate
Bottom Outlet (Optional Kit).....	See Accessories

**DIMENSIONS**

Inside Diameter (Inches)	Inside Height at Center (Inches)	Overall Height (Inches)	Overall Width (Inches)	Weight (Pounds)
9-1/2	9-1/2	13-13/16	13-3/8	21-1/2

**WARNING**

Static electricity is created by the flow of fluid through the pressure tank and hose. If all parts are not properly grounded, sparking may occur. Sparks can ignite vapors from solvents and the fluid being sprayed.

If static sparking, or slight shock, is experienced while using this equipment, stop spraying immediately.

Ground the pressure tank by connecting one end of a 12 gauge minimum ground wire to the pressure tank and the other end to a true earth ground. Local codes may have additional grounding requirements.

**Note**

(For non-direct drive models)

A tank with agitator assembly is shipped with the curved edge of the paddle down. When a steel insert container is used it is necessary to turn the bottom paddle upside down so that the flat side is down. In either position, the correct adjustment on the paddle position is with the end of the paddle hub flush with end of the shaft. This mounting should give 1/2 inch clearance between the edge of the paddle and the insert container.

**WARNING**

**Pressure Relief Procedure**

High pressure can cause a serious injury. Pressure is maintained in a pressure tank after the system has been shut down. Before attempting removal of fill plug or cover, pressure must be relieved using the following steps:

1. Turn off the main air supply to the tank.

2. Close air inlet valve located on tank air manifold.

3. Bleed off air in the tank by turning the air relief valve thumb screw counterclockwise. Wait until all the air has escaped through the valve before removing the pressure tank cover or fill plug.

4. Leave the air relief valve open until you have reinstalled the cover or fill plug.

Mix and prepare material to be used according to manufacturer's instructions. Strain material through a fine mesh screen to remove lumps, skin, and foreign matter that might enter and clog fluid passages and/or spray equipment.

1. Follow pressure relief procedures above.

- To add material to 2 gallon tanks, remove lid and pour directly into the tank or container.

**Note**

If desired, a U.S. or metric 1 gallon pail of fluid can be placed directly into the tank.

- Replace the lid assembly and tighten thumb screws (6) securely.
- The air supply to the tank should include a filter/water separator to filter dirt from the air and remove water and oil. Connect the air supply line to the tank inlet valve.
- Connect the material hose to fluid outlet ball valve (14).

**USING BOTTOM OUTLET PORT**

The pressure tank has a 1 inch NPT drain port in the bottom of the tank. Bottom outlet kits may be connected into the drain port. Use bottom outlet feature when top outlet is not desirable. Direct bottom outlet piping to either of two holes located in tank skirt. A dolly to raise the tank off the floor is not required.

**OPERATION**

- Close air inlet valve to tank. Turn handle on regulator counterclockwise until spring tension is relieved.
- Turn on air supply to tank.
- Open air inlet valve to tank.
- Open fluid outlet valve.
- Turn handle on tank pressure regulator clockwise to pressurize tank. Clockwise increases material pressure; coun-

terclockwise will decrease material pressure. If the tank has no regulator, adjust pressure at the source.

- Turn on atomization air to spray gun at source of supply.
- Test spray. For further instructions, see spray gun service bulletin SB-2-001.

**Note**

If tank has a hand agitator, agitate material periodically by turning crank slowly clockwise.

If an air motor drive is used, start the agitator by slowly opening the needle valve. Air motor speed should be regulated according to the nature of the material being agitated. The agitator should be running continuously while using the tank.



If using an air quick disconnect (Q.D.) at the inlet to the regulator at the pressure tank, do not disconnect the Q.D. while the tank is pressurized, unless the ball valve is closed. Doing so will allow tank pressure to quickly relieve, and can potentially pull paint back through the air regulator and air motor, depending upon the liquid level in the tank. Tank pressure should always be relieved by opening the pet cock (relief valve) or pulling the safety valve ring.

**PREVENTIVE MAINTENANCE**

To clean equipment, proceed as follows:

- Turn off the air supply.

- Follow pressure relief procedure on Pg. 3.
- Turn T-handle adjusting screw on tank fluid regulator counterclockwise until no spring pressure is felt.
- Loosen thumb screws (6), tip clamps (7) back, and tip lid (13) to one side of tank. Do not remove lid from tank.
- Loosen spray gun air cap retaining ring about three turns.
- Turn on air supply.
- Cup cloth over air cap on the gun and pull trigger. This will force material back through the hose into the tank.
- Empty and clean tank and parts that come into contact with material. Use a solvent compatible with material being used.
- Pour solvent into tank.
- Replace lid and tighten thumb screws and clamps.
- Spray until clean solvent appears.
- Repeat steps 4 through 8.

**LUBRICATION**

Refer to the service manual provided with the air motor for lubrication information.

The bearings in the agitator bearing assembly are impregnated with a special non-gumming oil. Therefore, additional lubrication is not required.

The agitator shaft seal does not require lubrication.

**SERVICE CHECKS**

CONDITION	CAUSE	CORRECTION
A. Air escaping from port on regulator cap.	1. Broken or damaged diaphragm.	1. Replace diaphragm.
B. Pressure creepage registered on gauge.	1. Dirty or worn valve seat in regulator.	1. Clean or replace valve seat.
C. Material tends to settle out rapidly.	1. Not enough agitation of material.	1. Increase agitation.
D. Air leakage at agitator seal.	1. Defective seal assembly.	1. Replace.
E. Paint getting into bearing assembly of agitator.	1. Paint level in tank too high. 2. Defective agitator shaft seal.	1. Do not fill tank above agitator bearing assembly. 2. Replace.
F. Fluid or air leak at lid gasket.	1. Thumb screw not tight. 2. Defective lid gasket.	1. Tighten. 2. Replace.
G. Air mixing with paint.	1. Fluid tube not sealed to lid. 2. Excessive agitation.	1. Tighten fluid tube into lid. 2. Reduce speed of agitator.

NOTE: Occasionally check pressure gauge. The needle should return to zero with no pressure on the gauge.

**2 Gallon Galvanized Steel Tanks  
Exploded View**

Refer to Accessories for optional agitator and drives.

Refer to Accessories for regulator options.

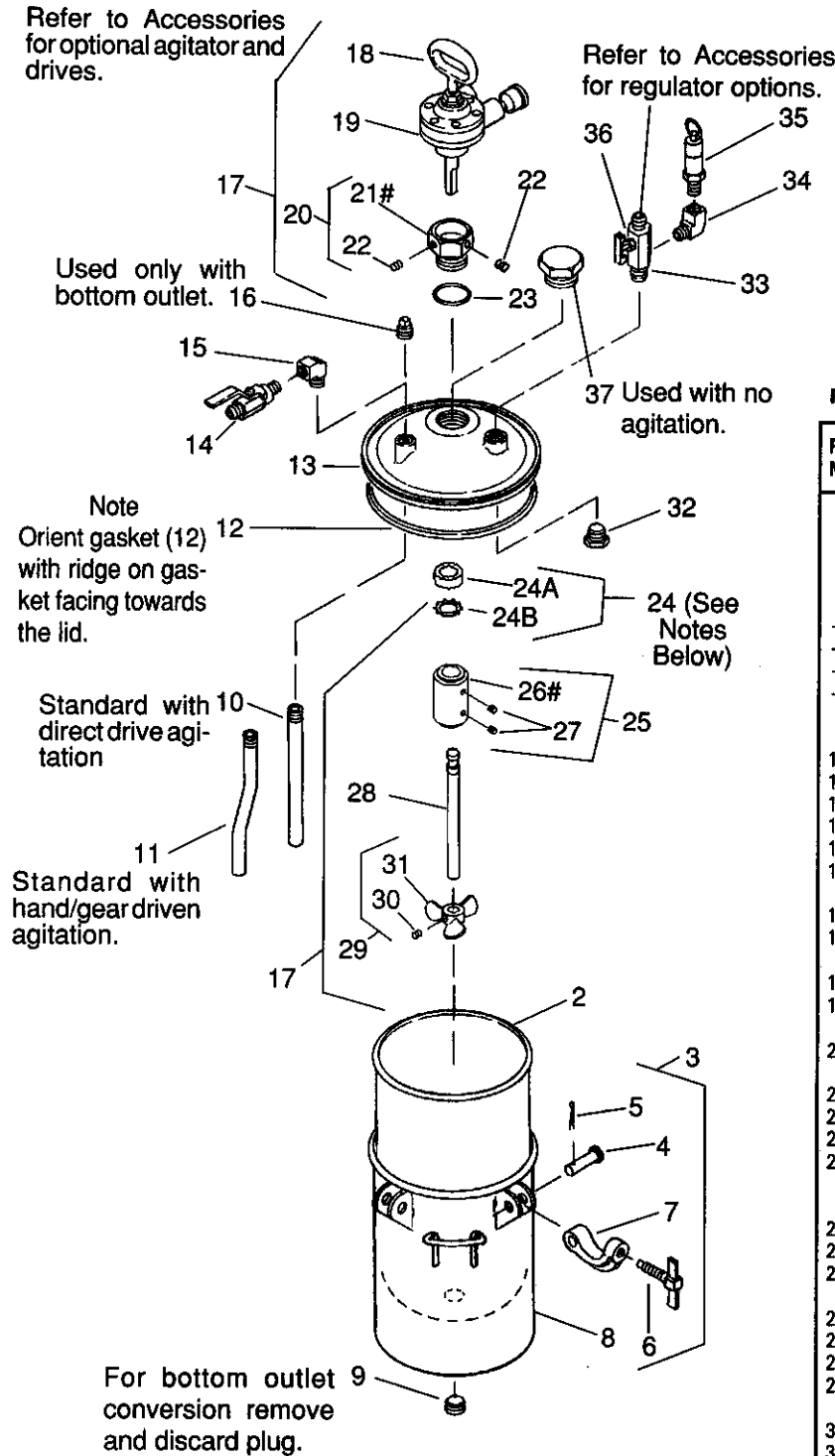

Note  
Orient gasket (12) with ridge on gasket facing towards the lid.

Standard with direct drive agitation

Standard with hand/gear driven agitation.

For bottom outlet conversion remove and discard plug.

Open side of Shaft Seal (24A) faces downward.

Note

Use a Teflon based thread sealant on all air/fluid connections.

Retainer (24B) required only if tank is used for vacuum operation.

**Parts List for Galvanized Steel 2 Gallon Paint Tanks**

Ref No.	Replacement Part Number	Description	Individual Parts Req.
1	----	Not Used	
2	PT-52-K10, K80	Disposable Tank Liner (10 or 80 each)	1
3	QMG-424	Tank Assembly Kit (includes items 4 through 8)	1
+4	----	Clevis Pin	4
+5	----	Cotter Pin (1/8 dia x 1 in. lg.)	4
+6	QMG-46	Thumb Screw	4
+7	----	Clamp	4
8	----	Tank, Galvanized Steel	1
9	----	Plug	1
10	PT-31	Fluid Tube (direct drive agitator)	1
11	QMG-35	Fluid Tube	1
12	QMS-80-K2	Lid Gasket, Thiokol (Kit of 2)	1
13	QMG-400	Tank Lid, Galvanized Steel	1
14	VA-540	Ball Valve	1
15	----	90° St. Elbow (3/8-18 NPT(F) (Brass)	1
16	----	Plug (3/8-18 NPT s.s.)	1
17	QMG-416	Agitator Assembly Direct Drive (includes items 18 through 31)	1
18	QN-97	Carrying Handle	1
19	QMG-429	Air Motor (Refer to SB-19-087 for service parts)	1
20	KK-4990	Adapter Kit (Includes items 21, 22, 26, and 27)	1
21#	----	Adapter	1
22#	----	Setscrew (1/4-20 x 1/4)	4
23	SSG-8184-K2	O-Ring Kit (Kit of 2)	1
24	KK-5041	Shaft Seal Kit (Fits 1/2" shaft with direct drive air motor). See Pg. 8 for gear reduced models.	1
24A	----	Shaft Seal	1
24B	----	Retainer	1
25	KK-4990	Seal Retainer Kit (Includes items 21, 22, 26, & 27)	1
26#	----	Shaft Coupling	1
27#	----	Setscrew (1/4-20 x 3/8)	2
28	QMS-56	Agitator Shaft (5/8")	1
29	QMG-448	Agitator Propeller Kit (includes items 30 & 31)	1
30	----	Setscrew (1/4-20 x 3/8,)	1
31	----	Agitator Propeller	1
32	----	Plug (1/2-14 NPT)	1
33	QMG-21	Air Manifold	1
34	----	Street Elbow (1/4-18 NPT Brass)	1
35	TIA-5110	Safety Valve Assembly, 110 psi	1
	TIA-5040	Safety Valve Assy., 40 psi (for tanks with extra sensitive regulation)	1
36	SS-2705	Air Relief Valve	1
37	QMG-17	Plug	1

# When replacing either Ref. Nos. 21 or 26, you must order KK-4990 which includes both parts. + KK-5013 Clamp, Pin & Screw Kit includes 1 each of items 4, 5, 6 & 7. • Purchase locally.

**ACCESSORIES**

**QMS-435 BOTTOM OUTLET CONVERSION KIT**

Fittings that allow standard top outlet tank to feed from bottom by removing plug in bottom port. Kit includes stainless steel shutoff valve and all stainless steel parts.

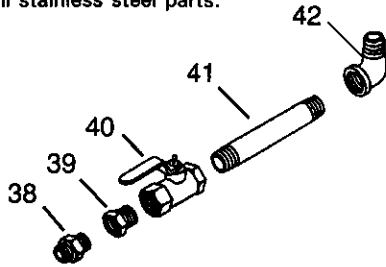

Ref. No.	Replacement Part No.	Description	Qty.
38	----	Adapter, 3/8" NPT to 3/4-14 NPS(M) s.s.	1
39	----	Reducer Bushing, 3/4 to 1" s.s.	1
40	----	Ball Valve, 1 x 1 NPT(F) s.s. 150 PSI	1
41	----	Pipe Nipple	1
42	----	Street Elbow (3/4")	1

**QM-142 HAND CRANK**

Mounts on agitator shaft to provide manual agitation of materials in tank.

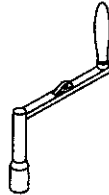

**QMS-4003 NO REGULATION KIT**

Use when fluid pressure in tank is regulated by some other separate controls. Kit includes air shutoff valve, gauge to read fluid pressure in tank, and fittings.

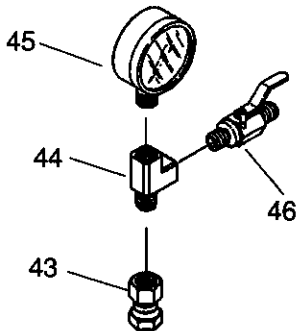

Ref No.	Replacement Part No.	Description	Qty
43•	----	Swivel Coupling 1/4 NPS(M) x 1/4 NPT(F)	1
44•	----	Street Tee (1/4")	1
45	GA-288	Gauge 160 lb	1
46	VA-542	Valve	1

**QMS-4006 SINGLE REGULATOR KIT**

Provides standard fluid pressure control only. For use when atomization air is controlled by a separate filter-regulator. Kit includes pressure regulator with gauge, inlet and outlet shutoff valves, and connection fittings. Refer to SB-6-162 for regulator service parts.

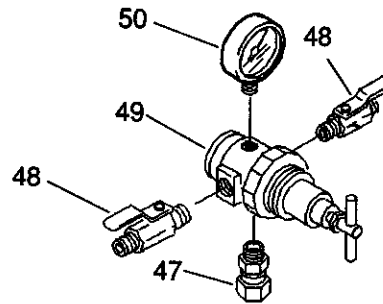

Ref No.	Replacement Part No.	Description	Qty
47	SSP-8217-ZN	Swivel Adapter	1
48	VA-542	Valve	2
49	HAR-502	Regulator (painted)	1
50	GA-288	Gauge 160 lb (painted)	1

**QMS-4007 DUAL REGULATOR KIT**

Provides independent controls for fluid pressure in tank and atomization air pressure. Kit includes two regulators with gauges, inlet and outlet shutoff valves, and connection fittings. Refer to SB-6-162 for regulator service parts.

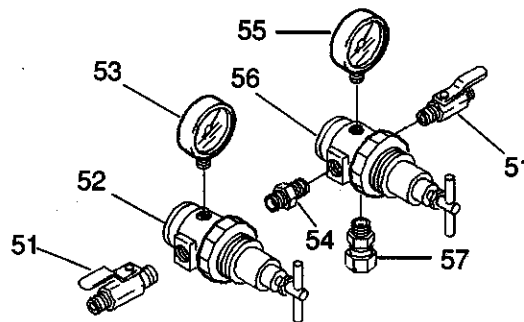

Ref No.	Replacement Part No.	Description	Qty
51	VA-542	Valve	2
52	HAR-505	Regulator (Painted)	1
53	GA-333	Gauge, 100 lbs. (Ptd.)	1
54	SSP-438-NI	Hex Nipple	1
55	GA-288	Gauge, 160 lbs. (Ptd.)	1
56	HAR-502	Regulator (Painted)	1
57	SSP-8217-ZN	Swivel Adapter	1

**QMS-4010 EXTRA SENSITIVE REGULATOR KIT**

Use with electrostatic spray or other applications requiring extremely sensitive nonfluctuating low pressure control. Kit includes one extra sensitive gauge, one extra sensitive regulator, inlet and outlet shutoff valves, and connection fittings. Refer to SB-6-131 for regulator service parts.

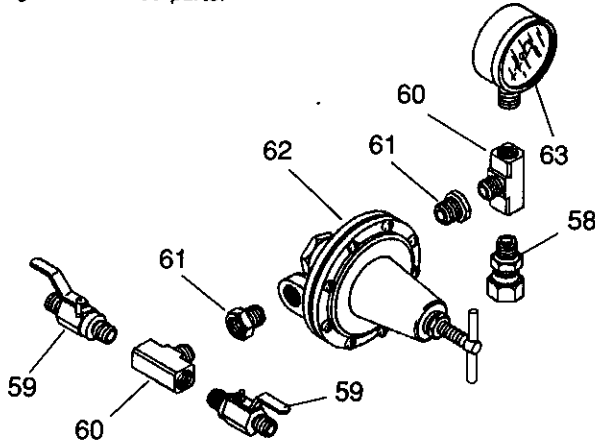

Ref No.	Replacement Part No.	Description	Qty
58	SSP-8217-ZN	Swivel Adapter	1
59	VA-542	Valve	2
60	SSP-2629-ZN	Tee Male Branch	2
61•	----	Hex Reducer Bushing (3/8 x 1/4 Galvanized)	2
62	HAR-501	Extra Sensitive Regulator	1
63	GA-73	Gauge 30 lb	1

• Purchase locally.

**QMS-436 CONVERSION TO DOUBLE REGULATOR ASSEMBLY KIT**

Adapts to tanks equipped with single regulator to provide independent pressure control of atomization air and fluid pressures. Converts QMS-4006 single regulator to a QMS-4007 dual regulator. Refer to SB-6-162 for regulator service parts.

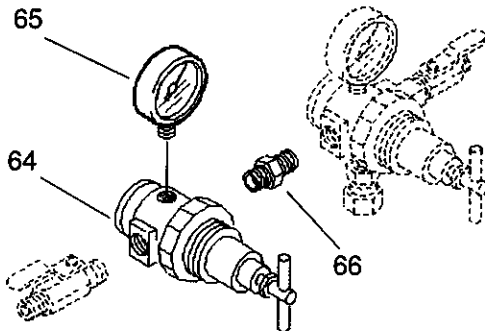

Ref No.	Replacement Part No.	Description	Qty
64	HAR-505	Regulator	1
65	GA-333	Gauge	1
66	SSP-438-Ni	Hex Nipple	1

**VS-534 FLUID STRAINER**

Primary fluid strainer that attaches between fluid outlet valve and fluid hose to strain material. Components made of stainless steel with a nylon filter. Comes standard with 100-mesh screen. For more information see SB-7-072.



**QS-5012 AIR MOTOR DRIVE**

Standard duty 1/4 hp agitator drive with 15:1 gear reduction. Operates from 20 to 120 rpm. Mounts on agitator shaft. Includes throttling valve, fittings, and hose for connection to air supply on tank lid. Used with QMS-431 agitator assembly. For further information see SB-19-087.

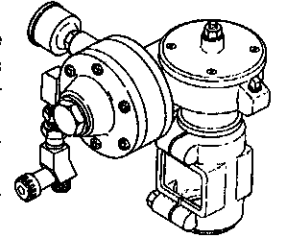

**QSR-503 RECIPROCATING AIR MOTOR DRIVE**

Low air consumption motor mounts easily on tanks equipped for material agitation. Slow back and forth motion ensures proper agitation. Operates at 1 to 40 strokes per minute. Used with QMS-431 agitator assembly. For more information see SB-19-222.

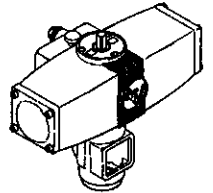

**DISPOSABLE TANK LINERS**

Molded polyethylene tank liners to reduce solvent waste and tank cleanup time. The liner is made of tough, durable, leakproof polyethylene and can be used with all compatible materials.

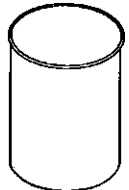

PT-52-K10 Kit of 10 tank liners  
PT-52-K80 Kit of 80 tank liners

**QMG-35 GALVANIZED BENT FLUID TUBE &  
QMS-79 SHORTER PROFILE AGITATOR PADDLE**

All hardware needed to provide agitation of materials in tank except drive, which must be selected separately.

**QMG-417 AGITATOR ASSEMBLY**

All hardware needed to provide agitation of materials in tank except air motor drive, which must be selected separately.

Ref No.	Replacement Part No.	Description	Qty
67	QMS-46	Retaining Nut	1
68	QMS-447	Thrust Collar Kit (includes items 69 and 70)	1
69	----	Thrust Collar	1
70*	----	Setscrew (5/16-18 x 3/8)	1
71	KK-5049	Thrust Washer Kit (2 washers in kit)	2
72	QMG-409	Bearing Assembly	1
73	SSG-8184-K2	O-Ring	1
74	KK-5042	Shaft Seal Kit (Fits 5/8" shaft with gear reduced air motors)	1
74A	----	Shaft Seal	1
74B	----	Retainer	1
75	QMG-15	Agitator Shaft	1
76	QMS-449	Agitator Propeller Kit (includes items 78 and 79)	1
77	----	Agitator Propeller	1
78*	----	Hex Socket Head Cap Screw (5/16-18 x 1-1/4, s.s.)	1

\* Purchase locally.

**WARRANTY**

This product is covered by DeVilbiss' 1 Year Limited Warranty. See SB-1-000 which is available upon request.

**DeVILBISS WORLDWIDE SALES AND SERVICE LISTING - [www.devilbiss.com](http://www.devilbiss.com)**

**INDUSTRIAL FINISHING** - DeVilbiss has authorized distributors throughout the world. **FOR TECHNICAL ASSISTANCE OR THE DISTRIBUTOR NEAREST YOU, CALL TOLL FREE 1-800-338-4448 (U.S.A. AND CANADA ONLY). FOR LOCAL CALLS, SEE LISTING BELOW.**

U.S./Canada Sales & Customer Service Office  
GLENDALE HEIGHTS, IL 60139

Address  
195 Internationale Blvd.

Telephone No.  
(630) 237-5000  
Toll Free Fax No. 1-877-790-6965

**AUTOMOTIVE REFINISHING** - DeVilbiss has authorized distributors throughout the world. For equipment, parts and service, check the Yellow Pages under "Automobile Body Shop Equipment and Supplies". **FOR TECHNICAL ASSISTANCE, CALL TOLL FREE 1-800-445-3988 (U.S.A. ONLY). FOR LOCAL CALLS, SEE LISTING BELOW.**

U.S. Customer Service Office  
MAUMEE, OH 43537

Address  
1724 Indian Wood Circle

Telephone No.  
(419) 891-8100  
Toll Free Fax No. 1-800-445-6643

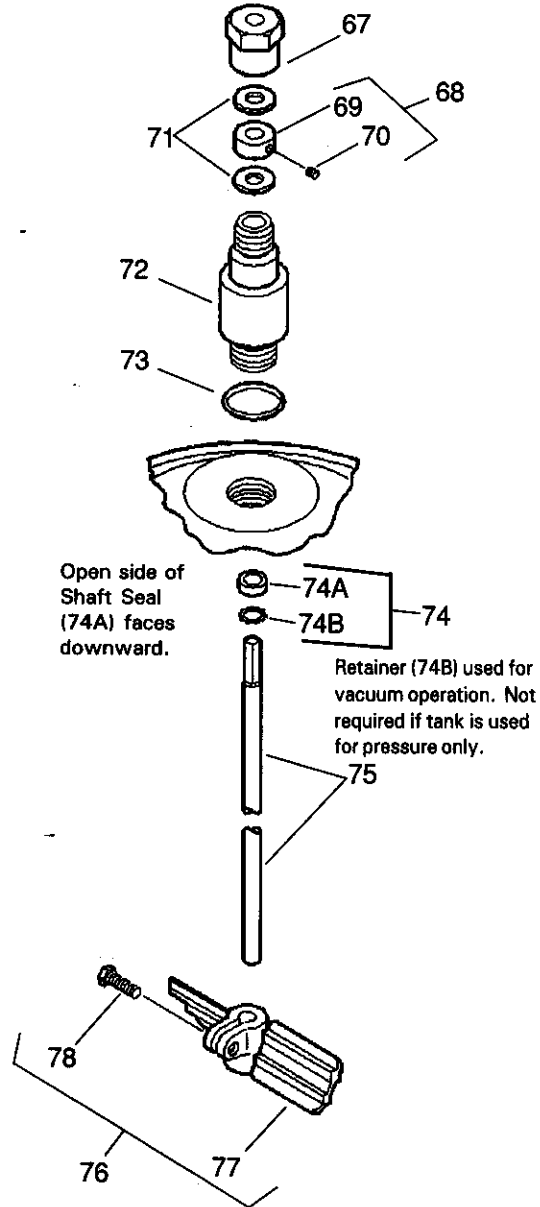

An Illinois Tool Works Company